

**IS6015 Magnetic Perimeter Seal**

Medium Duty



Refrigeration-type vinyl magnetic strip in anodised aluminium housing. The strip holds the door closed so latches are not always required.

This seal has proved to be an effective acoustic seal when tested in accordance with BS EN ISO 140-3: 1995. See Acoustic Sealing Systems for Door Assemblies manual for further details.

**Key Benefits**

- Concealed fixings, pre-drilled and slotted holes for easy adjustment.
- Easily installed without removing the door.
- Can be used as a stop.
- Can be supplied with magnetic keeper strip, IS6100 which has an aggressive self-adhesive backing for fixing to timber doors.

**Location**

Head and jambs of single swing steel clad doors and timber doors with IS6100 insert.

**Seal material**

- IS6015 – flexible vinyl with magnetic core.
- IS6100 – PVC sleeve with magnetic insert.

**Standard lengths**

1m and 2.1m. Other lengths and single doorset packs consisting of 1 x 1m and 2 x 2.1m available to special order.

**Fixing**

Wood screws are supplied (self-tapping screws for metal frames are available on request). Fixing holes are pre-drilled and slotted to allow the seals to be adjusted and positioned accurately. A PVC cover strip to conceal fixings is supplied.

*Note: order IS6100 magnetic keeper strip for use with timber doors. Supplied with self-adhesive backing as standard.*

**Finish**

- IS6015 – silver anodised aluminium with grey insert or bronze anodised aluminium with black insert.
- IS6100 – brown, cream or maple PVC sleeve. Other colours, including woodgrain finishes, to special order.

**Acoustic Performance**

- Weighted Sound Reduction Index (R<sub>w</sub>): 33dB.
- Sound Transmission Class (STC): 33dB.

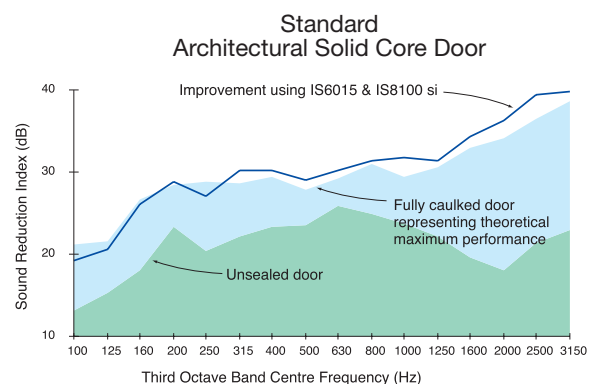
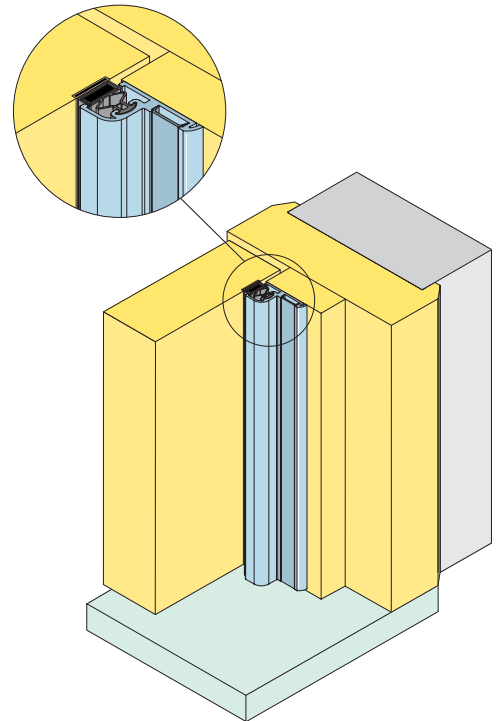
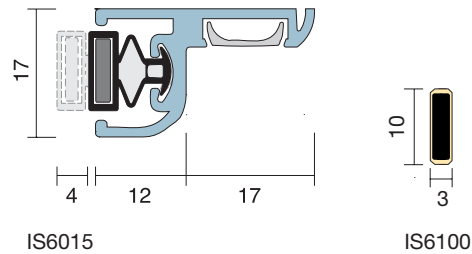

## IS6020 Magnetic Seal for Meeting Stiles

Medium Duty



This seal is an effective acoustic seal when tested in accordance with BS EN ISO 140-3: 1995. See Acoustic Sealing Systems for Door Assemblies manual for further details.

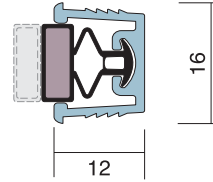

IS6020

### ■ Location

Rebated meeting stiles of double leaf doors.  
Sliding doors.

### ■ Seal material

Grey silicone rubber. Black insert to special order.

### ■ Standard lengths

2.1m. Other lengths to special order.

### ■ Fixing

The aluminium trough is toothed to lock into a 16mm x 12mm groove. The magnetic seals are also 'locked' in to prevent creeping.

### ■ Finish

Silver anodised aluminium with grey insert. Black insert to special order.

*Note: not suitable where centre latching is required.*

### ■ Acoustic performance

Weighted Sound Reduction (R<sub>w</sub>): 30dB

Sound Transmission Class (STC): 30dB

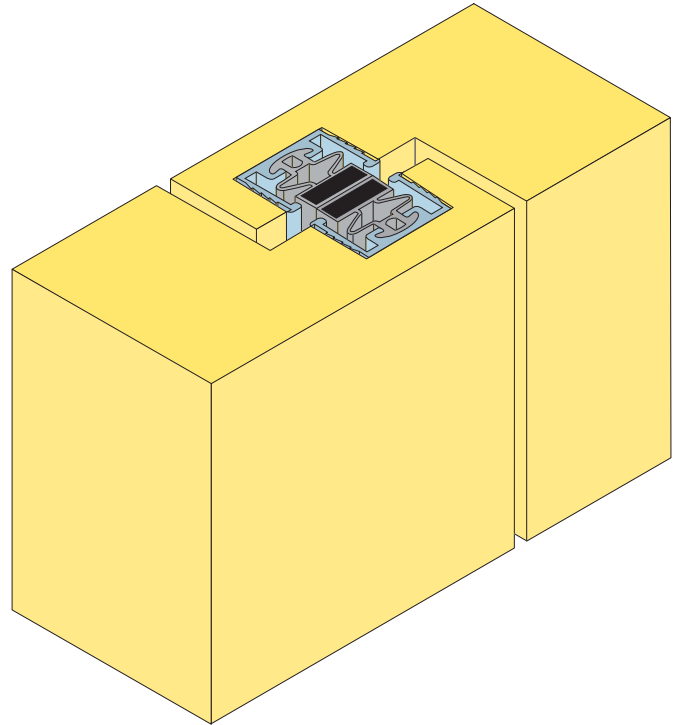

Standard  
Architectural Solid Core Door

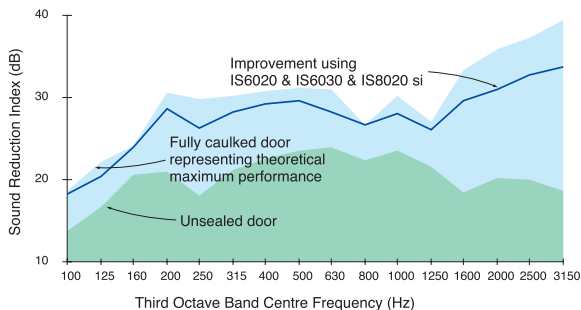

### IS6030 Magnetic Perimeter Seal

Medium Duty



Refrigeration-type vinyl magnetic strip in anodised aluminium housing. The strip holds the door closed so latches are not always required.

This seal has proved to be an effective acoustic seal when tested in accordance with BS EN ISO 140-3: 1995. See Acoustic Sealing Systems for Door Assemblies manual for further details.

#### ■ Key Benefits

- Durable anodised aesthetic finish.
- Concealed fixings, pre-drilled and slotted holes for easy adjustment.
- Easily installed without removing the door.
- Can be supplied with magnetic keeper strip, IS6100 which has an aggressive self-adhesive backing for fixing to timber doors.

#### ■ Location

Head and jambs of single swing steel clad doors and timber doors with IS6100 insert.

#### ■ Seal material

IS6030 – flexible vinyl with magnetic core.  
IS6100 – PVC sleeve with magnetic insert.

#### ■ Standard lengths

1m and 2.1m. Single doorset pack consisting of 1 x 1m and 2 x 2.1m. Other lengths to special order.

#### ■ Fixing

Wood screws are supplied (self-tapping screws for metal frames are available on request). Fixing holes are pre-drilled and slotted to allow the seals to be adjusted and positioned accurately. A PVC cover strip to conceal fixings is supplied.

*Note: order IS6100 magnetic keeper strip for use with timber doors. Supplied with self-adhesive backing as standard.*

#### ■ Finish

IS6030 – silver anodised aluminium with grey insert or bronze anodised aluminium with black insert.  
IS6100 – brown, cream or maple PVC sleeve. Other colours, including woodgrain finishes, to special order.

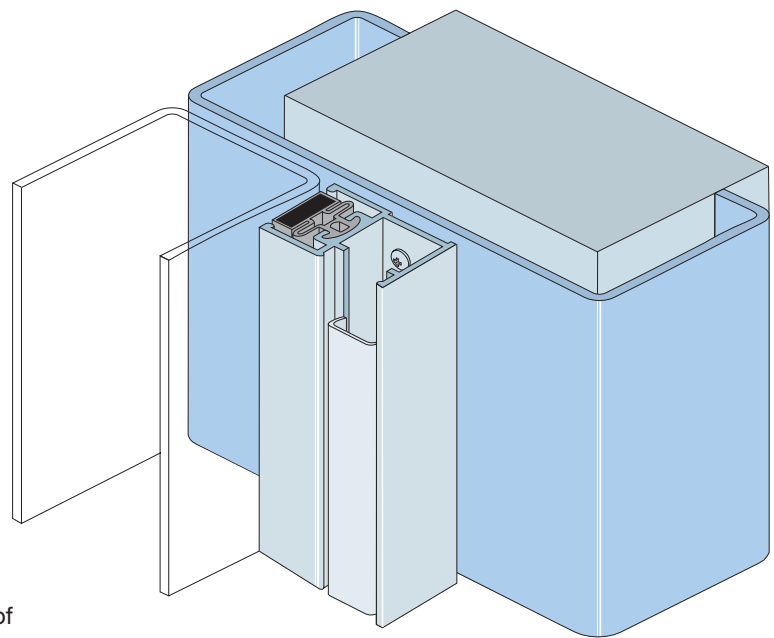
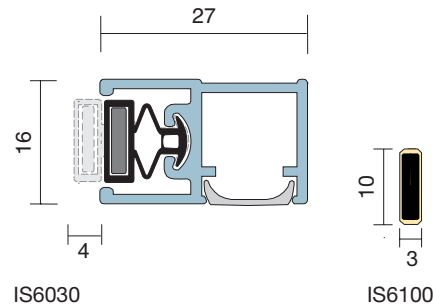

#### ■ Acoustic Performance

Weighted Sound Reduction Index (Rw): 33dB.  
Sound Transmission Class (STC): 33dB.

